

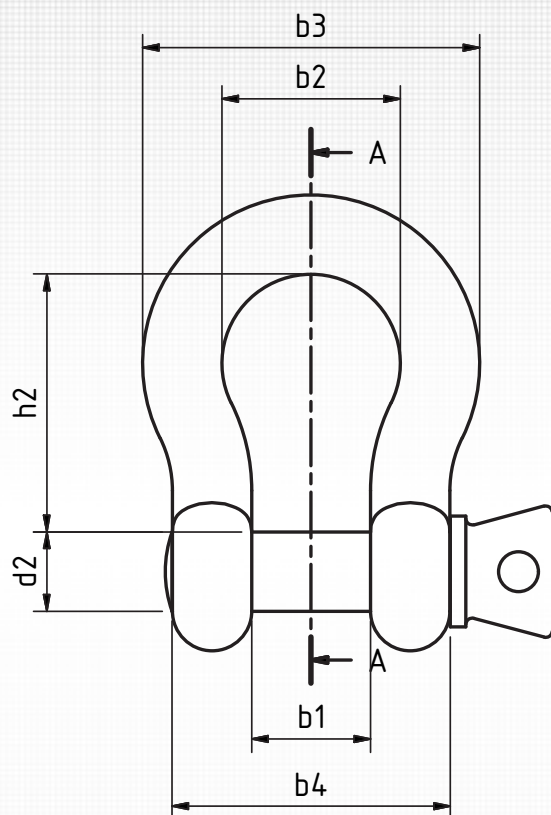

# DATENBLATT

A-A ( 1 : 2 )

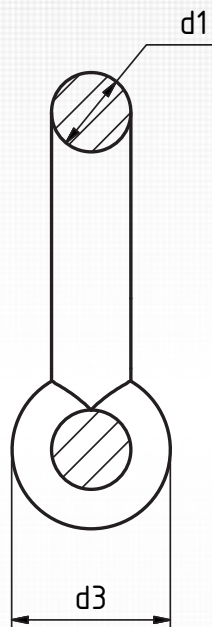

Alle Maße in mm

Artikel Nr.:	b1	b2	b3	b4	d1	d2	d3	h2	h3
HR0001	12	19	34	26	7,5	8	17,5	28	48
HR0003	16	25	45	36	10	11	24	36	63
HR0005	21	32	58	45	13	16	31	48	83
HR0006	26	42	74	57	16	19	40	62	105
HR0007	32	50	88	67	19	22	48	70	120
HR0008	36	57	100	79	23	25	54	82	143

Allgemeintoleranz		Projekt:		Massstab: 1:2		Menge:	
ISO 2768 - mK				Material: Standard		Wärmeb.:	
ISO 13920 - B				Oberfläche:		Bemerkung:	
		Datum		Name		Benennung:	
		Bearb. 25.06.2015		Sven Gruber		Runder Schäkel verzinkt 24 AFNOR	
		Gepr.					
		Norm					
						Zeichnungs-Nr.:	
						Schäkel	
Index		Änderungen		Datum		Name	
						Nur CAD-Änderungen gültig	
						Schutzvermerk nach DIN ISO 16016 beachten	
						Blatt: A4	

